

How To Order: FEF-51-XX-XX-XX

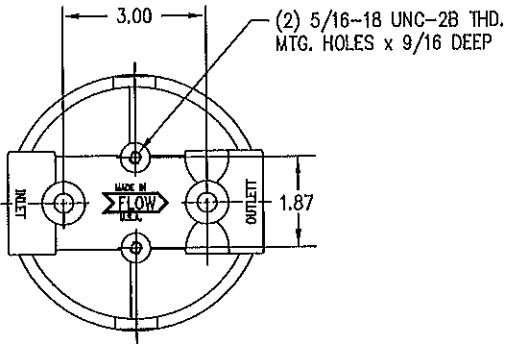

Code	Inlet & Outlet Ports
20	1 1/4" NPTF
24	1-1/2" NPTF
20S	1 5/8-12 UN (SAE - 20)

Code	Element
03	Micron Cellulose
10	Micron Cellulose
25	Micron Cellulose
100M	100 Mesh Stainless Steel Wire Cloth

Code	By-Pass Setting
00	No By-Pass
25	25 PSI

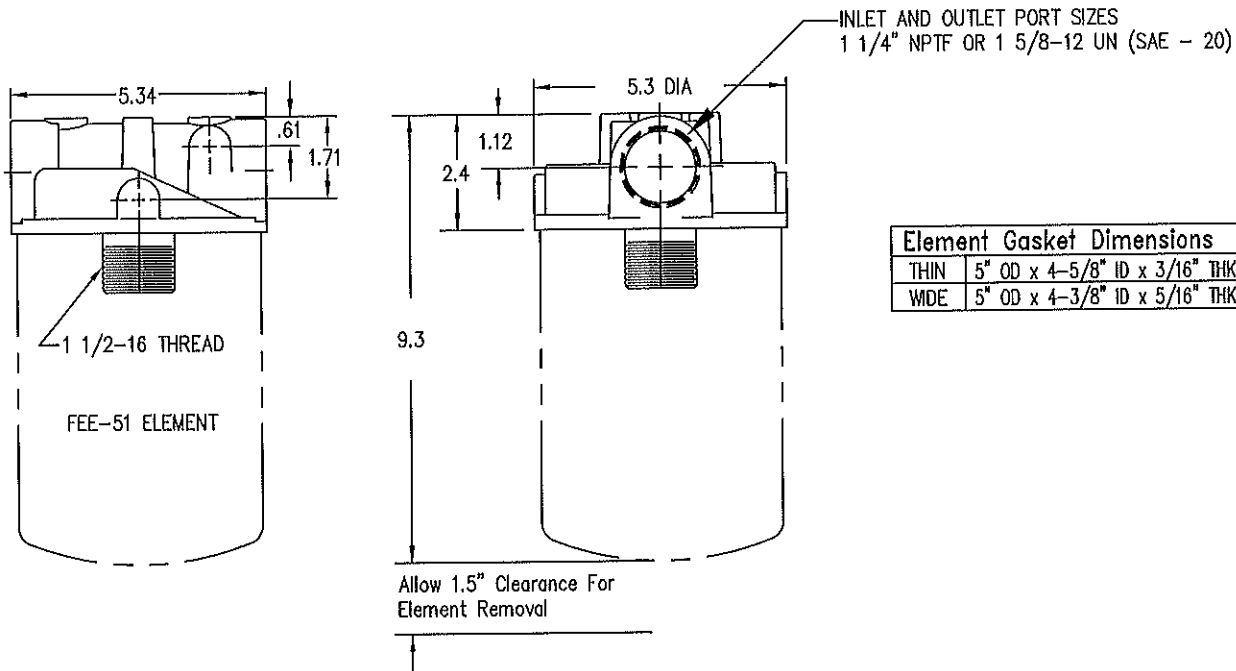

Average Pressure Drop Thru Clean Filter Assembly With 150 SSU Oil At 105° F.

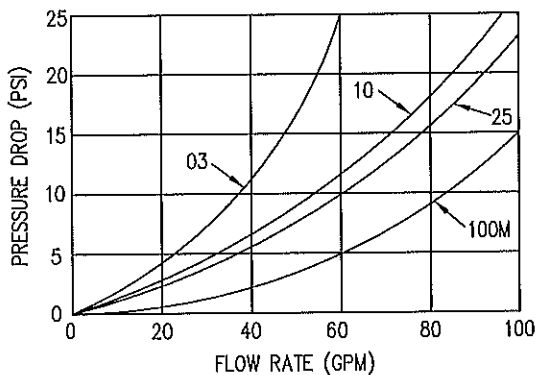

Flows Up To: 70 GPM (Return) 25 GPM (Suction)

Port Sizes: 1 1/4" NPTF
1 5/8 - 12 UN (SAE - 20)

Pressure: 200 PSI Max. operating
Warning: 80 PSI ΔP max. without by-pass valve.

Temperature: -65 to +250° F. Operating

Application: Petroleum based fluids only.

DISK FILE:
DBZIP-1
DRAWN BY:
D BALL
DATE:
09-29-06
SCALE:



FLOW EZY
FILTERS, INC.

TITLE FEF-51 SERIES
SPIN-ON FILTER

DRAWING NO. 12186-11