

# HYDRAULIC FLANGES

- 4-BOLT SAE DESIGN
- RATED FOR 3000 PSI PRESSURE
- SEVEN SIZES, 3/4 THROUGH 3-INCH
- FEMALE NPT THREADS



### MOUNTING HARDWARE KIT (optional)

O-ring (1),  
cap screws (4),  
lock washers (4)

### HOW TO ORDER FLANGES

Select the desired specifications from the dimension table and order by number, example: **W43-24P**

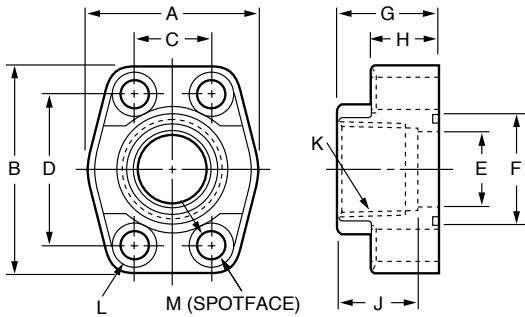

# PORTABLE FILTER SYSTEM

**Flow Ezy Portable Oil Transfer and Filter System has many applications for use in the plant or in the field**

- For fluid transfer from drums or storage tanks to system reservoir
- For fluid conditioning
- For filtering out system oil resulting from failure of system component
- Recirculating system oil without having to shut down
- Removal of water from oil (with optional 3rd stage, 3 micron water removal filter)
- Clean-up contaminated hydraulic oils

Standard filter gives you 2 filters instead of 1. First stage filters at 25 micron and the second at 10. Two models are available, one with a 5 gpm rating and one with a 10 gpm rating. Very economical way to protect the system from damage caused by contamination.



### HOW TO ORDER

MODEL	COARSE FILTER	POLISHING FILTER	WITH 3RD STAGE WATER REMOVAL FILTER
JD100 (5 GPM)	25c	10C	
JD110 (10 GPM)	25C	10C	
JD 100 (5 GPM)	25C	10C	3W
JD 110 (10 GPM)	25C	10C	3W
REPLACEMENT ELEMENTS	FEE-51-25	FEE-51-10	LE3AZ

Model Number	Nominal Flange Size	A	B	C ±0.010	D ±0.010	E DIA.	F DIA.	G	H	J	K NPTF Thread	L DIA.	M Spotface	SOC HD CAP SCREW	"O" RING ARP-568 Uniform Dash
W43-12P	3/4	2.06	2.56	0.875	1.875	0.75	1.255 / 1.250	1.25	.84	.87	3/4	.406	.594	3/8-16 x 1-1/2"	-214
W43-16P	1	2.31	2.75	1.031	2.062	1.00	1.565 / 1.560	1.37	.97	1.12	1	.406	.594	3/8-16 x 1-1/2"	-219
W43-20P	1-1/4	2.88	3.12	1.188	2.312	1.25	1.755 / 1.750	1.50	1.03	1.12	1-1/4	.469	.656	7/16-14 x 1-3/4"	-222
W43-24P	1-1/2	3.25	3.69	1.406	2.750	1.50	2.125 / 2.115	1.62	1.09	1.12	1-1/2	.531	.781	1/2-13 x 1-3/4"	-225
W43-32P	2	3.81	4.00	1.688	3.062	2.00	2.500 / 2.490	1.62	1.09	1.12	2	.531	.781	1/2-13 x 1-3/4"	-228
W43-40P	2-1/2	4.28	4.50	2.00	3.500	2.50	3.005 / 2.995	2.00	1.47	1.56	2-1/2	.531	.781	1/2-13 x 1-3/4"	-232
W43-48P	3	5.16	5.31	2.438	4.188	3.00	3.625 / 3.615	2.25	1.59	1.72	3	.656	.937	5/8-11 x 2"	-237